

WOOFER GDN 17/50/6

9 5151 286

TECHNICAL DATA

Rated impedance	4	Ω
Voice coil resistance	3,4	Ω
Voice coil inductance	0,345	mH@1K
Rated frequency range	80 to 6000	Hz
Resonance frequency	45	Hz
Power handling capacity / enclosure 9 dm ³ , 100 h continuous /	40	W
Max. power	80	W
Sensitivity	91	dB
Flux density	0,98	T
Energy in air gap	218	mJ
Force factor - Bl	5,21	Tm
Piston area - S _D	106,4 x 10 ⁻⁴	m ²
Total moving mass - M _{MS}	0,0104	kg
Compliance /loudspeaker unmounted/ - C _{MS}	1,19 x 10 ⁻³	m/N
Equivalent box volume - V _{AS}	0,019	m ³
Quality factor /loudspeaker unmounted/		
- mechanical - Q _{MS}	5,17	
- electrical - Q _{ES}	0,385	
- total - Q _{TS}	0,36	
Air - gap	25/6,2/1,125	mm
Voice coil height	9	mm
Magnet		
- material	ferite	
- dimensions	83/31/15	mm
- mass	0,35	kg
Mass of loudspeaker	0,95	kg

The loudspeaker has a polypropylene cone, a rubber surround and a plastic frame.

AVAILABLE VERSIONS

GDN 17/50/6 - 4 Ω , catalogue number 9 5151 286

Kapton voice coil former, black cone, plastic dust cap, anthracite frame.

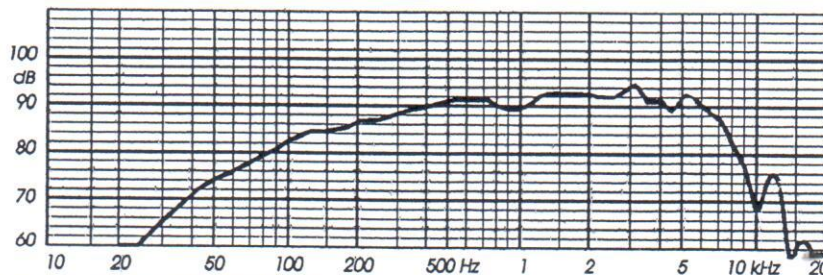
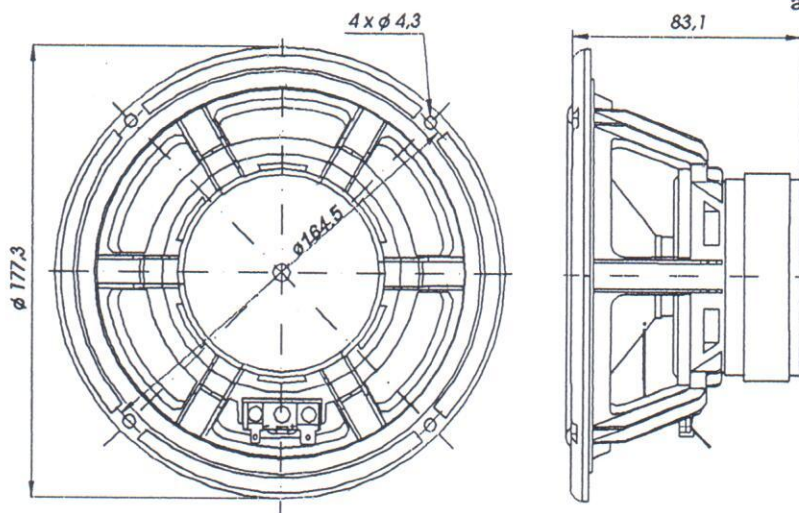

FREQUENCY RESPONSE CURVE

Measured in anechoic room at 1W/1m. Loudspeaker mounted in sealed 9 dm³ enclosure.

POLAND - WRZEŚNIA

TONSIL

TEL (061) 4 36 91 11

(061) 4 36 91 12

FAX (061) 4 376 190